

Bend Tool

Description		Wb02 Socket Wall Arm 35Cm		
UNLESS OTHERWISE SPECIFIED: DIMENSIONS ARE IN MILLIMETERS		Mod Date	19/01/2018	REVISION
		Drawn Date:	14/11/2006	
SURFACE FINISH: Powder Coated				A-003
DRAWN Ricky Clarke		Material		Bend & Machine Number
Unicol Engineering Green Road Oxford OX3 8EU		Gauge		
		DWG NO.		WB02
		WEIGHT:		Kg
		SCALE:1:4		DO NOT SCALE DRAWING
				SHEET 1 OF 3

All Fixings must be approved by a builder or architect and these are only shown for illustrational purposes

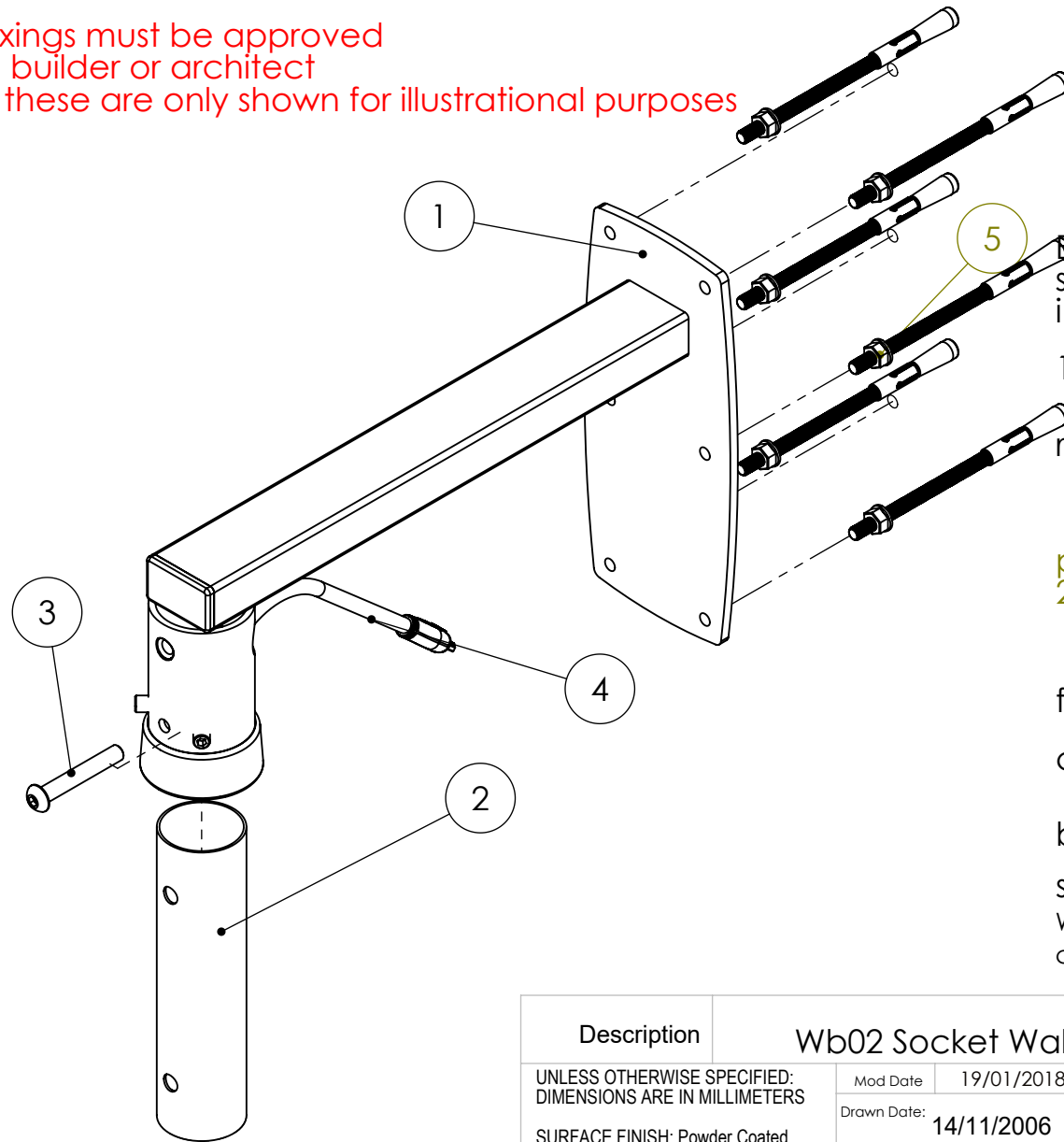

Ensure that the wall structure can support five times the load - (screen including all bracketry and peripherals).

1. Fix wall plate (1) to wall using reliable fixings (5) to ensure safe installation - Consult your builder or architect if in doubt, (fixings not provided).
2. Route cables through aperture in socket (4) and through column (2) before fixing column to wall arm. Insert column (2) into (1) using safety through bolt (3) to fasten together - nip up grub screws.

WARNING - Safety Through Bolts must be used to connect columns to wall plates and mount adapters.

Description		Wb02 Socket Wall Arm 35Cm		
UNLESS OTHERWISE SPECIFIED: DIMENSIONS ARE IN MILLIMETERS	Mod Date	19/01/2018	REVISION	Bend & Machine Number
	Drawn Date:	14/11/2006	A-003	
SURFACE FINISH: Powder Coated				
DRAWN	Ricky Clarke	Material		
Unicol Engineering Green Road Oxford OX3 8EU		Gauge		DWG NO.
				<b>WB02</b>
				A4

Bend V Tool

1

2

3

WEIGHT:

Kg

SCALE:1:4

DO NOT SCALE DRAWING

SHEET 2 OF 3

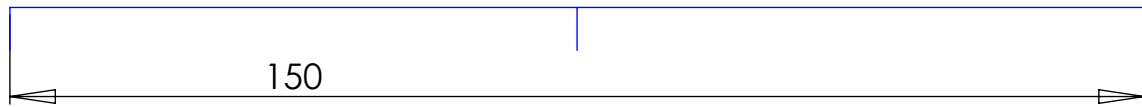
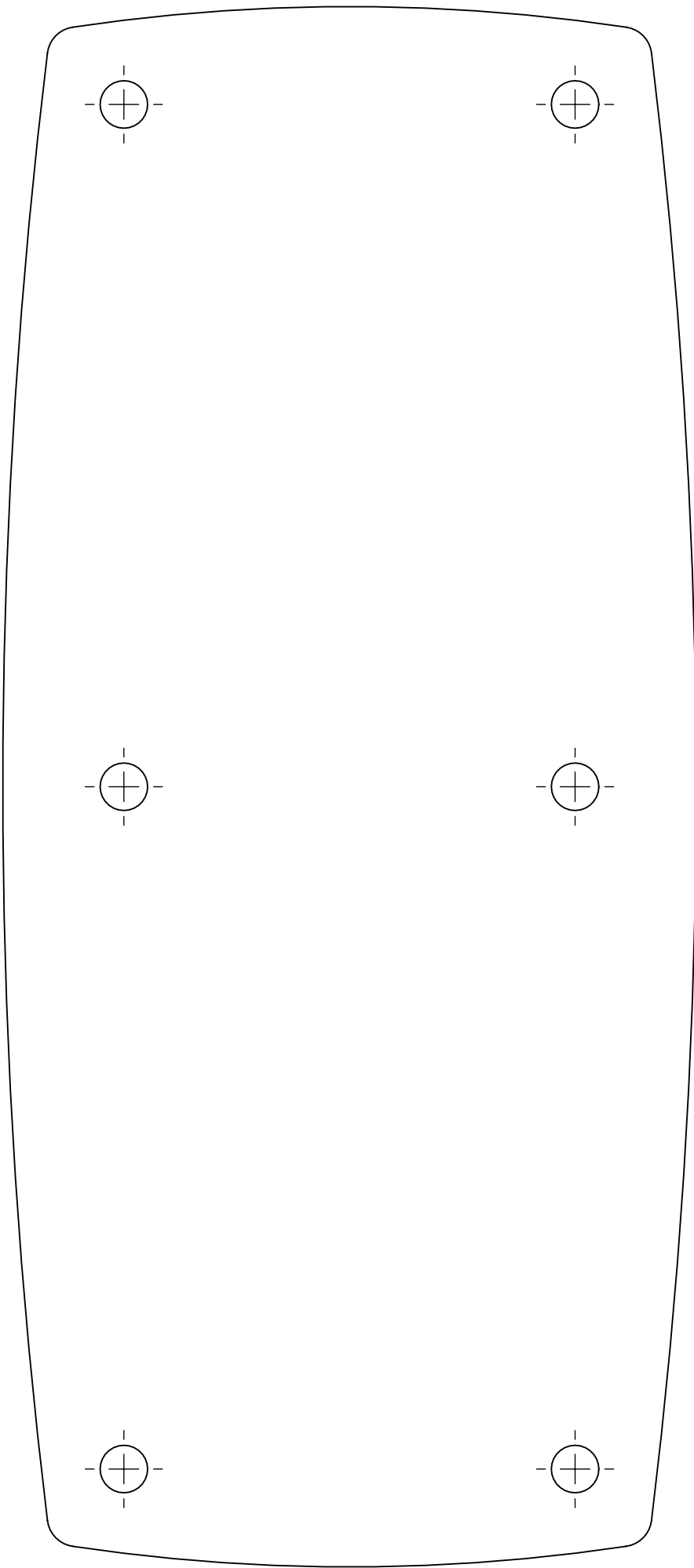

Check Scale when printing

Description		WB1228 Back Plate only		
UNLESS OTHERWISE SPECIFIED: DIMENSIONS ARE IN MILLIMETERS	Mod Date	26/02/2018	REVISION	Bend & Machine Number
	Drawn Date:	14/11/2006	A-003	
SURFACE FINISH: Powder Coated	DRAWN	Ricky Clark	Material	MILD STEEL
Unicol Engineering Green Road Oxford OX3 8EU	Gauge	6.0	DWG NO.	WB02
	WEIGHT:	Kg	SCALE:1:1	DO NOT SCALE DRAWING
				SHEET 3 OF 3

Bend V Tool

1

2

3

A4