

Description		Vwp1 - Pull Push Video Wall Unit 300 to 600 Vesa 40 - 70inch			
UNLESS OTHERWISE SPECIFIED: DIMENSIONS ARE IN MILLIMETERS		Mod Date	07/11/2019	REVISION	
SURFACE FINISH: Powder Coated		Drawn Date:	10/01/2013	A-086	
DRAWN Ricky Clark		Material			
Unicol Engineering Green Road Oxford OX3 8EU		Gauge			
		Bend & Machine Number		M6 X 16 Pozi 4 off , M8 X 16 Pozi 4 off, Plus 2 Additional Lifter handwheels 40mm	
		DWG NO.		Ass--20015776	
		WEIGHT: 14.56		Kg	
		SCALE:1:10		DO NOT SCALE DRAWING	
		SHEET 1 OF 2		A4	

Bend Tool

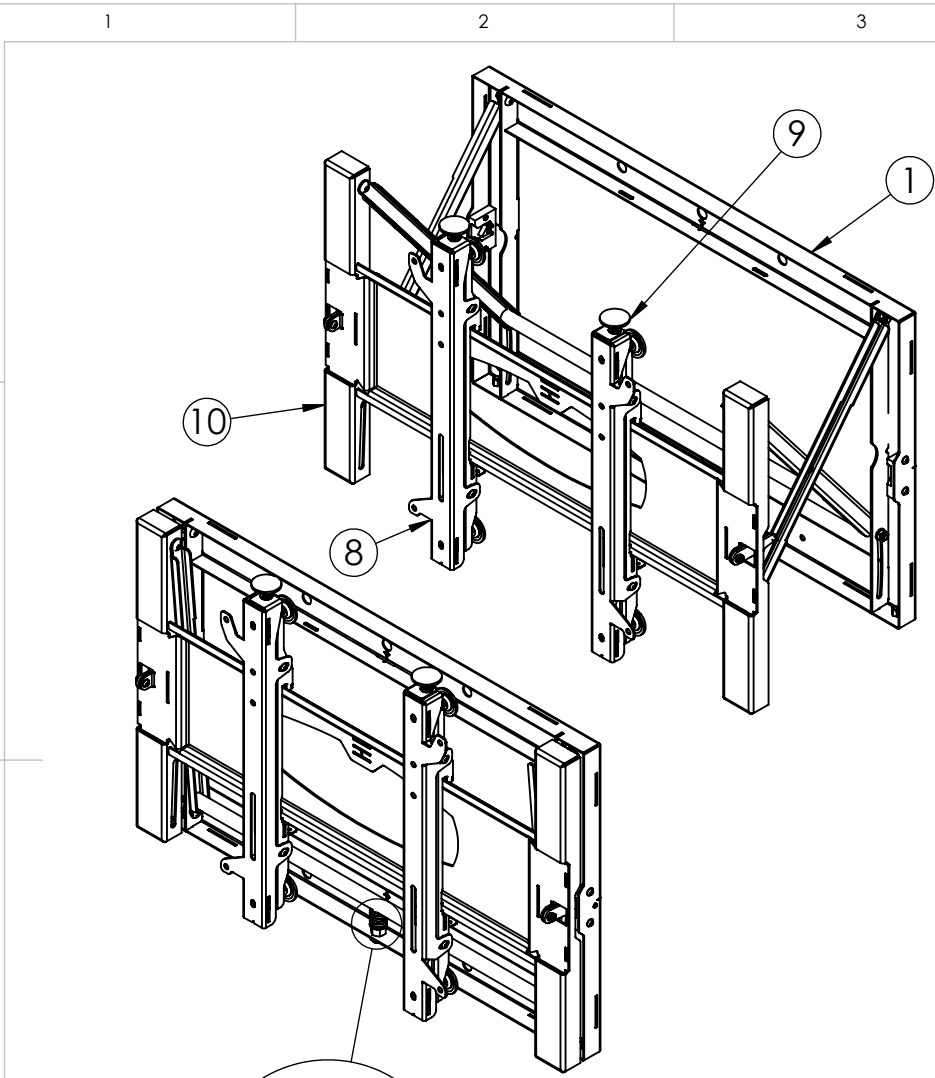

BOM Table			
NO	Part Number	Description	QTY.
1	Ass--20015767	Vwp1 - Wall Plate	1
2	HMS-MET-12X35-HT-BO	Hex Machine Screw M12 X 35 (High Tensile Black Oxide)	1
3	Ass--20016126	Spring Ass For Pop Out Video Wall	1
4	Ass--20015769	Vwp1 - Bottom Scissor Frame	1
5	Par--20025527	Scissor Arm	2
6	FW-MET-8-HT-CZN	Flat Washer M8 (High Tensile Bright Zinc Plated Clear Passivated)	20
7	BH-MET-8X20-HT-BO	Button Head Screw M8 X 20 (High Tensile Black Oxide)	7
8	Ass--20017471	Video Wall Arm 200 - 300 - 400 Extension Tabs Left	1
9	Ass--20017472	Video Wall Arm 200 - 300 - 400 Extension Tabs Right	1
10	Ass--20015670	Vwp1 Front Slider Arms Support	1
11	Par--20017909	Nylon Bush 5.25 X 10 X 10	2
12	BN-MET-8-HT-CZN	Binx Nut M8 (High Tensile Bright Zinc Plated Clear Passivated)	9
13	BH-MET-8X20-HT-CZN	Button Head Screw M8 X 20 (High Tensile Bright Zinc Plated Clear Passivated)	2

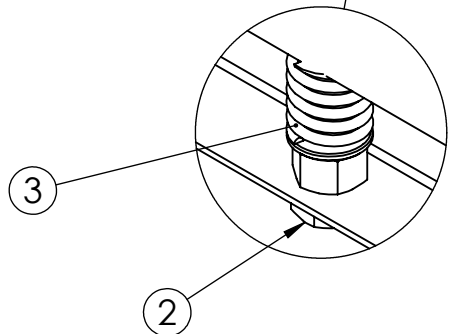

Description		Vwp1 - Pull Push Video Wall Unit 300 to 600 Vesa 40 - 70inch		
UNLESS OTHERWISE SPECIFIED: DIMENSIONS ARE IN MILLIMETERS	Mod Date	07/11/2019	REVISION	
	Drawn Date:	10/01/2013	A-086	
SURFACE FINISH: Powder Coated		Material		Bend & Machine Number
DRAWN Ricky Clark		Gauge		
Unicol Engineering Green Road Oxford OX3 8EU		DWG NO.		Ass--20015776
		A4		

Bend V Tool