

1 2 3 4 5 6

A

A

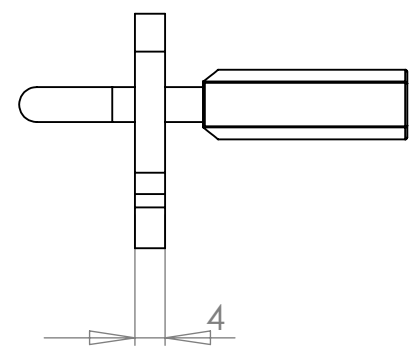
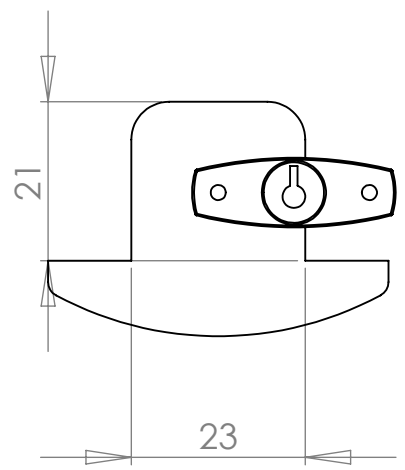

B

B

C

C

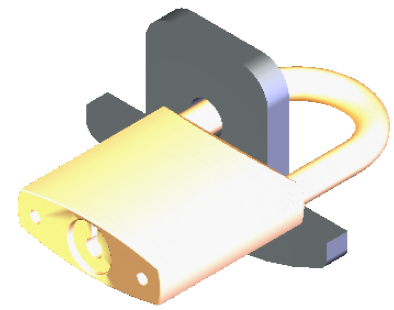
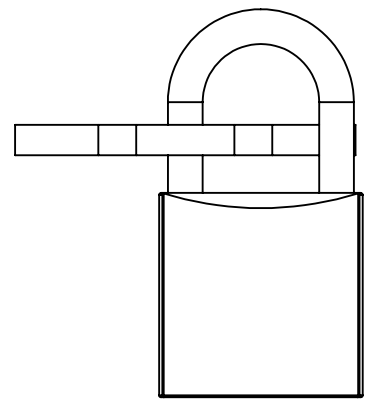

D

Bend Tool

Description		Tlk Taglock Kit			
UNLESS OTHERWISE SPECIFIED: DIMENSIONS ARE IN MILLIMETERS		Mod Date	22/11/2018	REVISION	Bend & Machine Number
SURFACE FINISH: Powder Coated		Drawn Date:	18/12/2007	A-004	
DRAWN	Ricky Clark	Material			
Unicol Engineering Green Road Oxford OX3 8EU		Gauge			DWG NO.
					TLK
					A4
		WEIGHT:	Kg	SCALE:1:1	DO NOT SCALE DRAWING
				SHEET 1 OF 2	

1 2 3 4 5 6

Guard box Not Included
Shown with 2 off TLK

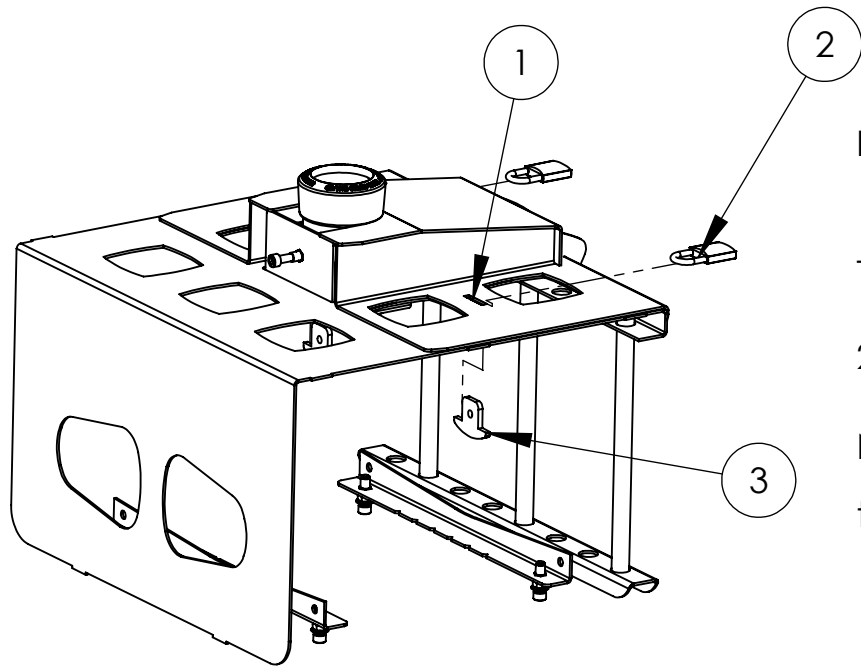

Instructions

1. Reach into fully assembled guard box and slide T plate (3) of TLK through either the left or right side slot (1)
2. Thread the open lock (2) through the hole of the exposed T plate

Note this is an additional security feature. Like all security devices they are security deterrents

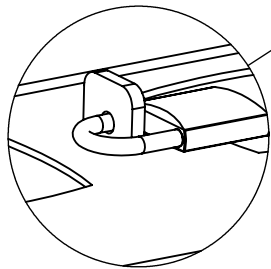
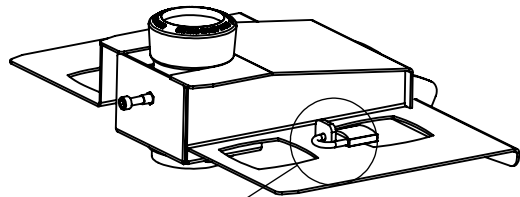

Description		Tlk Taglock Kit			
UNLESS OTHERWISE SPECIFIED: DIMENSIONS ARE IN MILLIMETERS	Mod Date	22/11/2018	REVISION	Bend & Machine Number	
	Drawn Date:	18/12/2007	A-004		
SURFACE FINISH: Powder Coated		Material			
DRAWN Ricky Clark	Unicol Engineering Green Road Oxford OX3 8EU		Gauge	DWG NO. TLK	
				A4	
WEIGHT:		Kg		SCALE:1:6	DO NOT SCALE DRAWING
				SHEET 2 OF 2	

Bend V Tool

1

2

3

WEIGHT:

Kg

SCALE:1:6

DO NOT SCALE DRAWING

SHEET 2 OF 2