

BOM Table			
NO	Part Number	Description	QTY.
1	Par--20021062	Pozimount Type 0 Back Panel	1
2	Par--20036515	Pozimount Type 0 Front Arms Tilting	2
3	Par--20002971	Pzw Inner Arm	2
4	Par--20002973	Nylon Washer 40 X 8 X 1.5	4
8	Par--20002972	Universal Bracket End Arms Tag PZW	4
9	Par--20037938	COMPRESION SPRING OD.970 FL1.75 W.095 (Low Load)	2
10	Par--20002574	Rivnut	4
12	Par--20002969	GLS Griplock Spacer	2
13	Par--20002970	GLT Griplock Tags	2
14	FRI-MET-10-PS-CZN	Flat Head Full Hex Body Rivnut M10	4

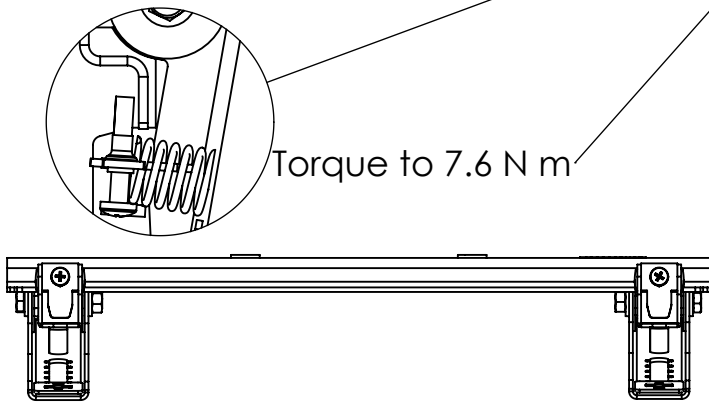

Description		Pzw0 Pozimount Type 0 Tilting	
UNLESS OTHERWISE SPECIFIED: DIMENSIONS ARE IN MILLIMETERS	Saved Date: 26 August 2021	DRW - REV REV - A-009	See Below - Special Notes
	Created Date: 06 April 2023		
SURFACE FINISH: Powder Coated	Bend Tool:	Material:	Part Number & Part Revision
	Created By System Administrator		
Unicol Engineering Green Road Oxford OX3 8EU		Ass--20024072 REV - A-009	

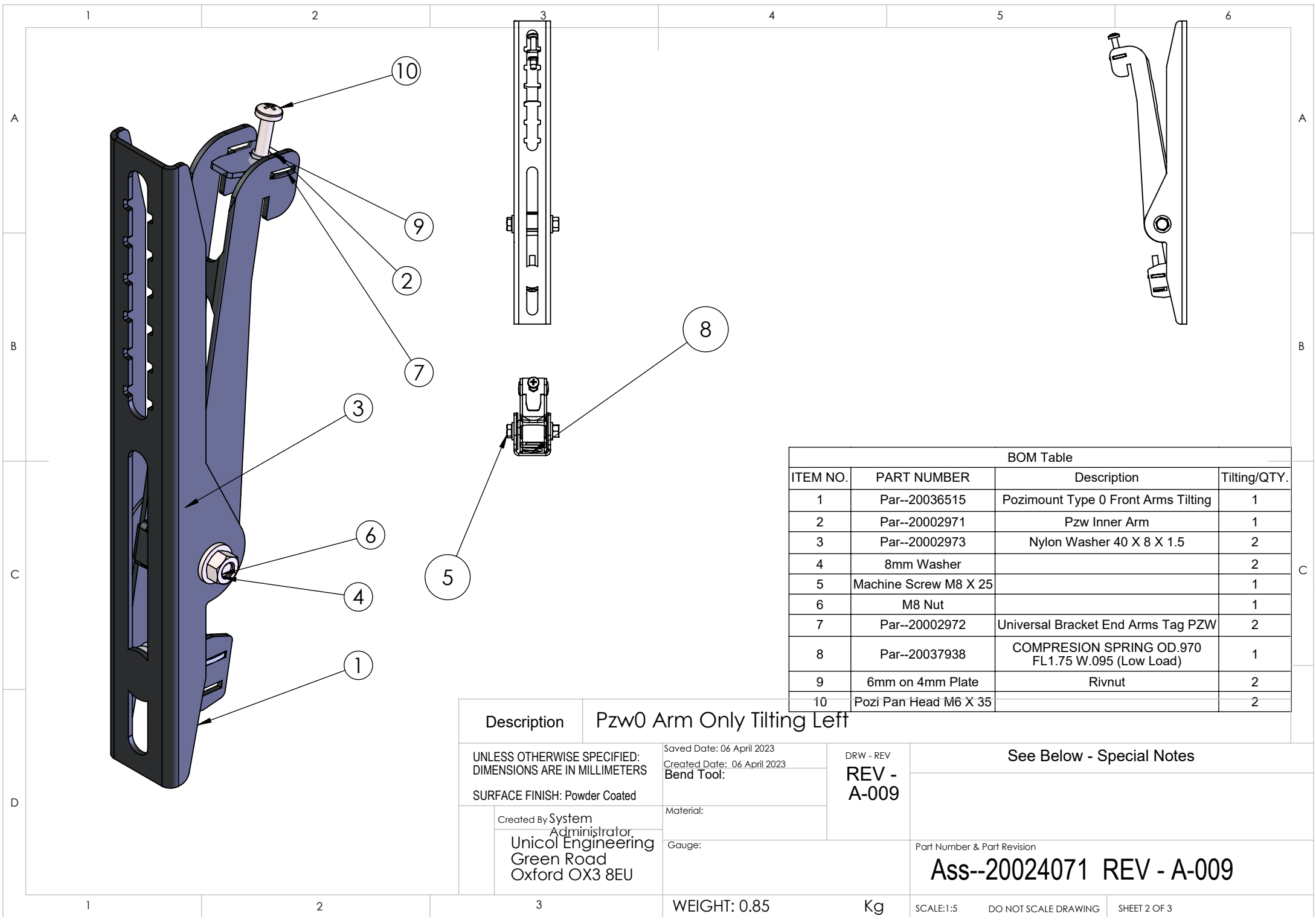

BOM Table			
ITEM NO.	PART NUMBER	Description	Tilting/QTY.
1	Par--20036515	Pozimount Type 0 Front Arms Tilting	1
2	Par--20002971	Pzw Inner Arm	1
3	Par--20002973	Nylon Washer 40 X 8 X 1.5	2
4	8mm Washer		2
5	Machine Screw M8 X 25		1
6	M8 Nut		1
7	Par--20002972	Universal Bracket End Arms Tag PZW	2
8	Par--20037938	COMPRESION SPRING OD.970 FL1.75 W.095 (Low Load)	1
9	6mm on 4mm Plate	Rivnut	2
10	Pozi Pan Head M6 X 35		2

Description		Pzw0 Arm Only Tilting Left	
UNLESS OTHERWISE SPECIFIED: DIMENSIONS ARE IN MILLIMETERS	Created By	System Administrator	DRW - REV REV - A-009
	Created By	System Administrator	
SURFACE FINISH: Powder Coated	Material:		See Below - Special Notes
	Gauge:		
Unicol Engineering Green Road Oxford OX3 8EU	Part Number & Part Revision		Ass--20024071 REV - A-009

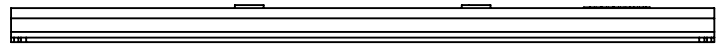
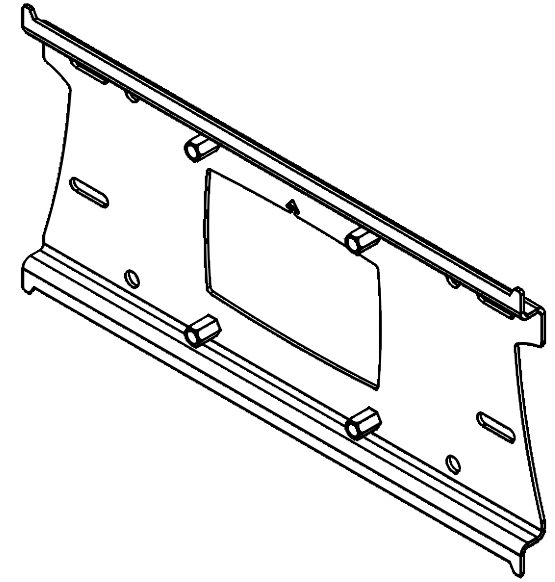
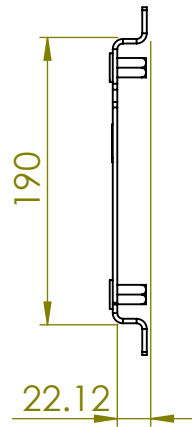
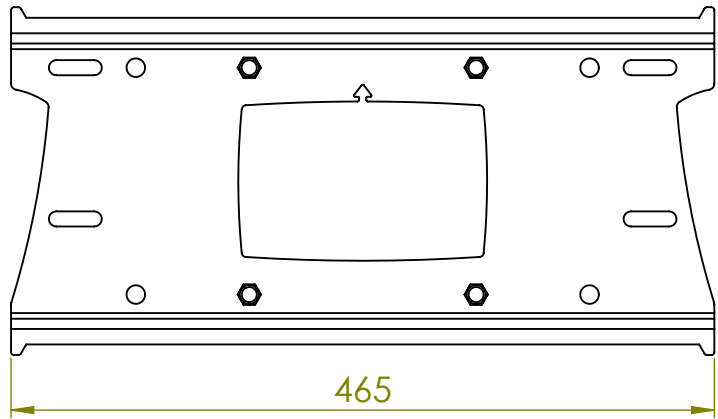

BOM Table			
NO	Part Number	Description	QTY.
1	Par--20021062	Pozimount Type 0 Back Panel	1
2	FRI-MET-10-PS-CZN	Flat Head Full Hex Body Rivnut M10	4

Description		PZX0 Back Plate Only	
UNLESS OTHERWISE SPECIFIED: DIMENSIONS ARE IN MILLIMETERS		Saved Date: 26 August 2021 Created Date: 06 April 2023 Bend Tool:	
SURFACE FINISH: Powder Coated		DRW - REV REV - A-009	
Created By Dennis Neale		Material:	
Unicol Engineering Green Road Oxford OX3 8EU		Gauge:	

See Below - Special Notes	
Part Number & Part Revision Ass--20025050 REV - A-009	