

Description		Md2u Pzaa Compatible Back Plate 35Cm			
UNLESS OTHERWISE SPECIFIED: DIMENSIONS ARE IN MILLIMETERS	Mod Date	17/08/2015	REVISION	Bend & Machine Number	
	Drawn Date:	14/03/2012			A-001
SURFACE FINISH: Powder Coated	DRAWN Robert Seward		Material	DWG NO.	
	Unicol Engineering Green Road Oxford OX3 8EU				Gauge
Bend Tool	WEIGHT: 1.84		Kg	A4	
1		2		3	
1		2		3	

### INSTALLATION INSTRUCTIONS

Parts List					
ITEM NO.	DESCRIPTION	3x3 46Inch QTY.	3x3 55 Inch QTY.	4x3 46 Inch QTY.	4x3 55 Inch QTY.
1	2000mm Column	4	4	4	4
2	Adjustment Jack	2	2	2	2
3	Back Plate 70Cm	0	0	0	3
4	Back Plate 140cm	6	0	0	0
5	Back Plate 180cm	0	6	6	6
6	Back Plate Joiner	3	3	3	6
7	Free Standing Twin Column Base	2	2	2	2
8	M10 Hex Nut	36	36	36	48
9	M10 x 16 Socket Button Head Cap Screw	12	12	12	24
10	M10 x 25 Hex Head Screw	24	24	24	24
11	Mult Screen Clamp Left	3	3	3	3
12	Mult Screen Clamp Right	3	3	3	3
13	Screen Mounting Arms Pair	9	9	12	12

4x3 55 Inch Shown

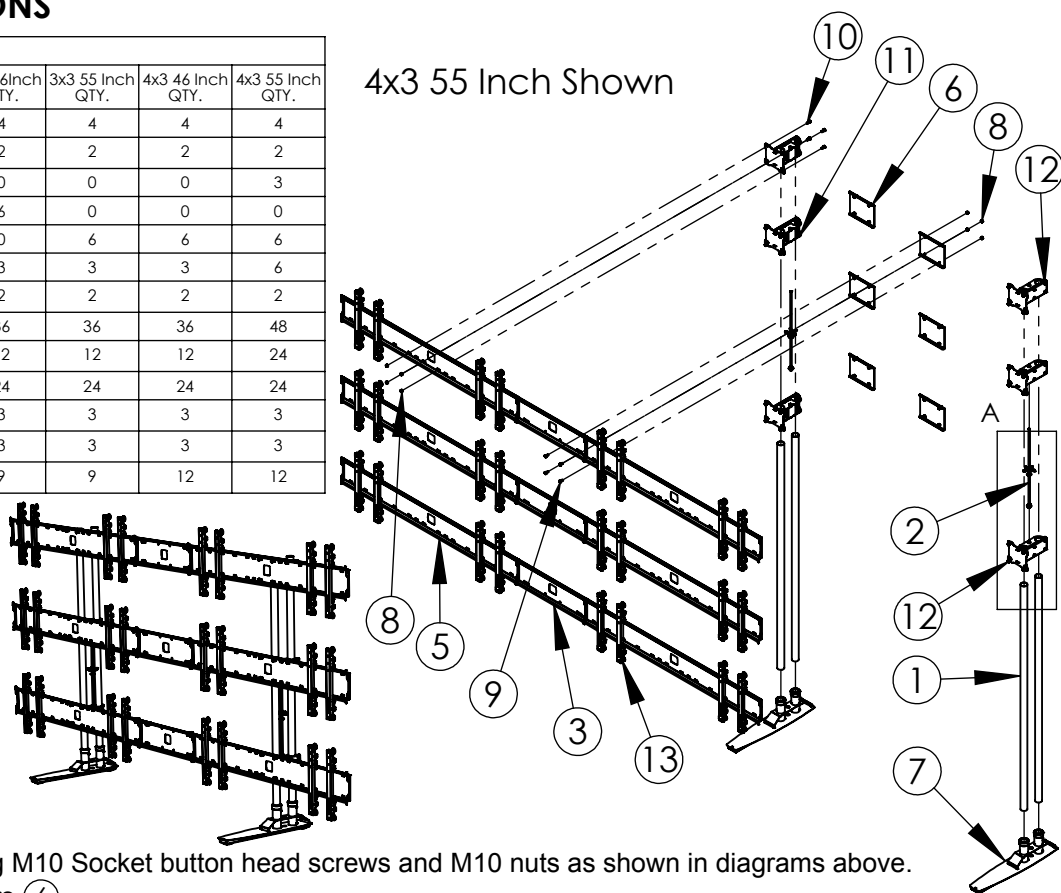

1. Join all back plates together using M10 Socket button head screws and M10 nuts as shown in diagrams above. Fit back plates with back plate joiners (6).

2. Place columns (1) into free standing twin column bases (7) until they stop and secure with grub screws.

3. Fit multi screen clamps (11) (12) to columns (1) do not fully tighten at this point just enough to stop sliding.

4. Attach back plate assemblies to multi screen clamps (11) (12) using (10) and (8).

5. Fix screen mounting arms (13) to screens and fit onto back plate assemblies.

6. Wind red handwheel down on adjustment jack (2) and slot top end of studding up into hole in underside of multi screen clamps (11) (12) and drop hex nut into corresponding hex cut out in top surface of multi screen clamps (11) (12). Wind hand wheels up to adjust height of back plate assemblies. This allows fine adjustment of screen row height.

7. When desired height is found. Mark thread on stud under hand wheel. Wind back hand wheel to remove adjustment jack (2). Repeat action 5 for next row up.

#### Inspect the unit before installing

**Warning:** Watch for pinch points. Do not put your fingers between moveable parts. Do not tamper with or dis-assemble any spring loaded items.

1. Carefully inspect the unit for shipping damage. If any damages apparent, call Unicol on number below.

2. Lay out components to ensure you have all the required parts before proceeding (see parts list).

**Caution:** To prevent damage to the unit, study all instructions and illustrations before you begin the installation. Failure to do so could render the warranty for the unit and the equipment that attaches to it null and void. Pay particular attention to the "warnings" displayed in these instructions.

We recommend installation by a qualified tradesperson. If you have any questions about the installation, contact Unicol, (uk +44 (0) 1865 767676) (europe +49 (0) 9131 9405 8013).