

Bend Tool

Description Column Drilling Jig

UNLESS OTHERWISE SPECIFIED:
DIMENSIONS ARE IN MILLIMETERS

Mod Date 08/03/2016

REVISION

See Below - Fixings Required

Drawn Date: 07/02/2008

A-004

SURFACE FINISH: Powder Coated

DRAWN Ricky Clark

Material

Unicol Engineering
Green Road
Oxford OX3 8EU

Gauge

DWG NO.

CDJ1

A4

WEIGHT: Kg

SCALE:1:2

DO NOT SCALE DRAWING

SHEET 1 OF 2

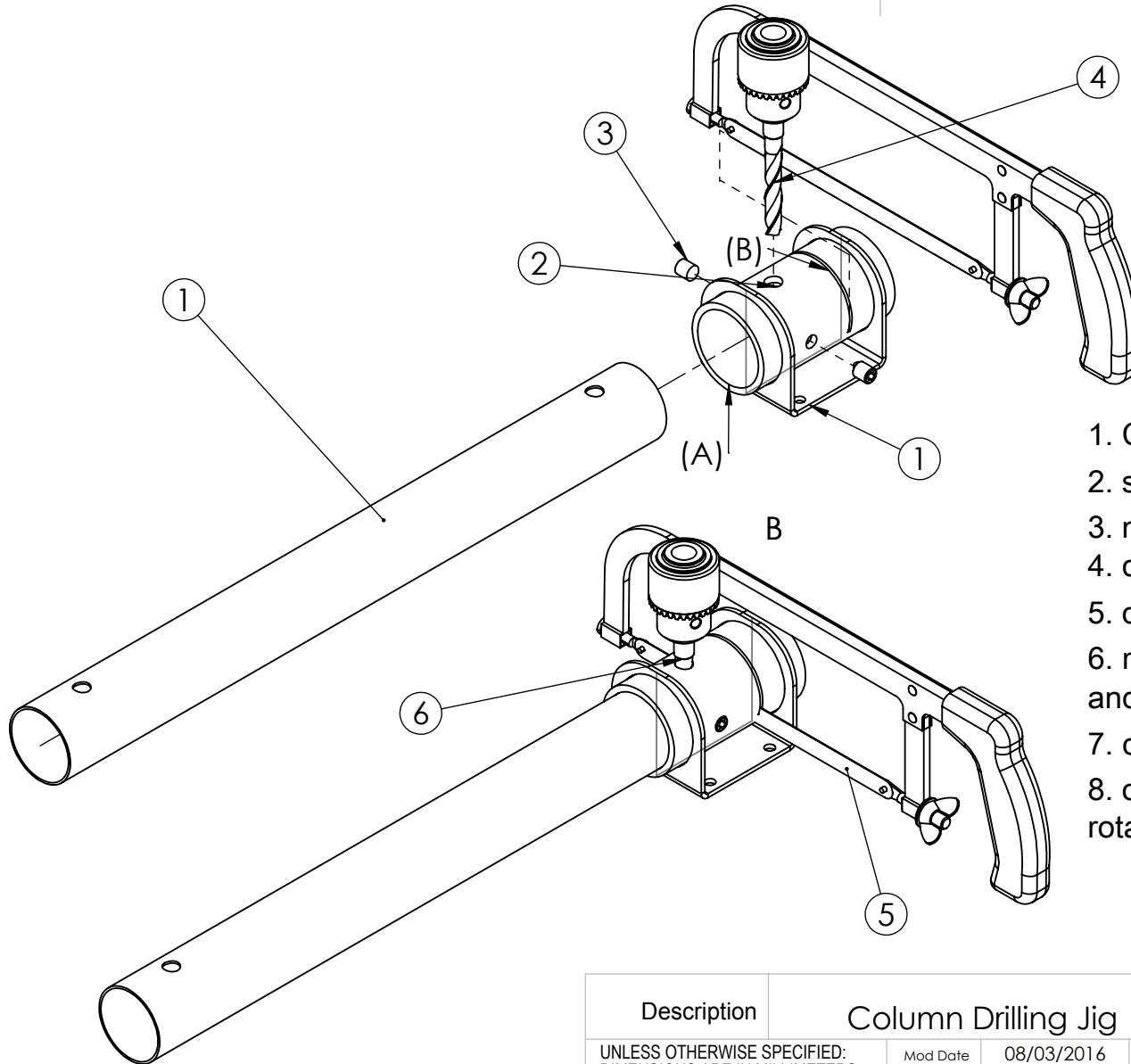

1. Clamp jig ① firmly in vice
2. slide column through jig ② direction (A)
3. measure length from (B) to end of column
4. clamp column using socket screws ③
5. drill ④ column passing through both sides
6. remove drill from chuck and put through column and jig as retainer pin ⑥
7. cut column using appropriate hack saw blade ⑤
8. once slightly past half way through column diameter, rotate column and complete cut

Description		Column Drilling Jig		
UNLESS OTHERWISE SPECIFIED: DIMENSIONS ARE IN MILLIMETERS	Mod Date	08/03/2016	REVISION	Bend & Machine Number
	Drawn Date:	07/02/2008	A-004	
SURFACE FINISH: Powder Coated				
DRAWN	Ricky Clark	Material		
Unicol Engineering Green Road Oxford OX3 8EU		Gauge		DWG NO.
				CDJ1
				A4

Bend V Tool

1

2

3

WEIGHT:

Kg

SCALE:1:4

DO NOT SCALE DRAWING

SHEET 2 OF 2