

3/8 bsf hand wheel

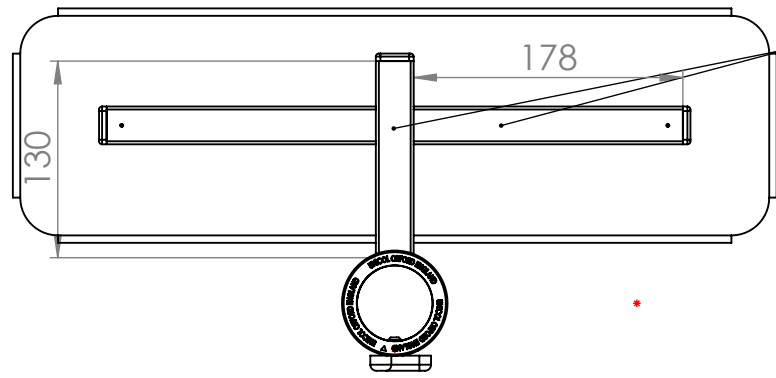

25x25: X2 178mm (7" Outrigger)  
X1 130mm

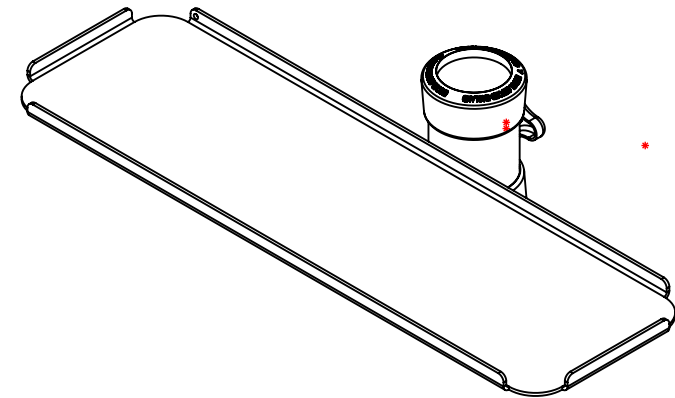
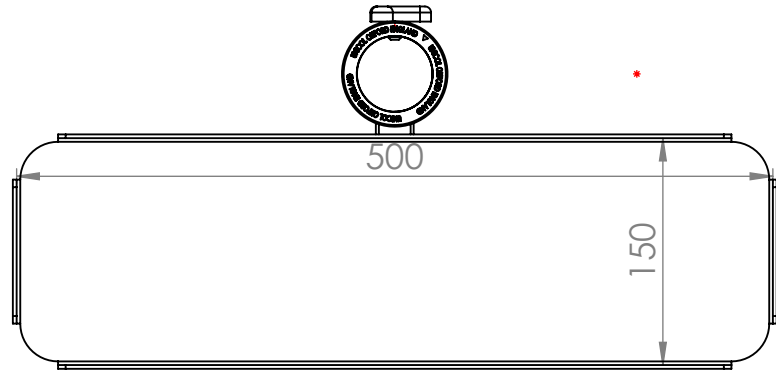

Description		Accessory Steel Platform		
UNLESS OTHERWISE SPECIFIED: DIMENSIONS ARE IN MILLIMETERS	Saved Date: 25 August 2021 Created Date: 27 August 2021 Bend Tool:		DRW - REV <b>REV - A-002</b>	See Below - Special Notes
	SURFACE FINISH: Powder Coated			
Created By System Administrator Unicol Engineering Green Road Oxford OX3 8EU	Material:		Part Number & Part Revision <b>Ass--20020283 REV - A-002</b>	
	Gauge:			
WEIGHT: 3.10		Kg		SCALE:1:5 DO NOT SCALE DRAWING SHEET 1 OF 1