

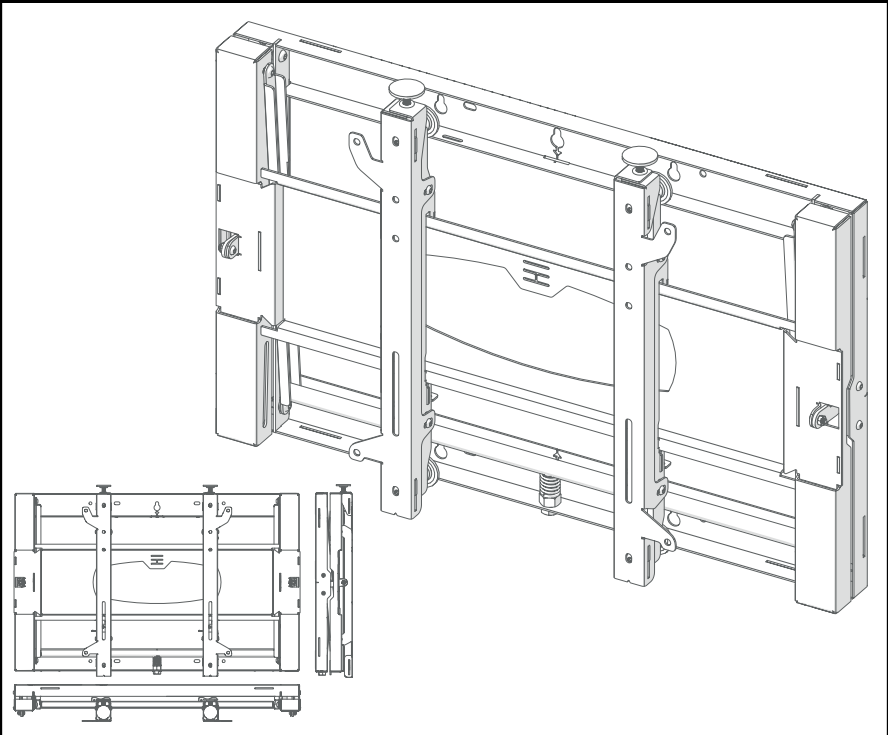

VWPO / VWP1 / VWP2 / VWP3 / VWP4 / VWPHD



Screen Size: 33-90" | **Guide Max. Weight:** 45-80kg

Please check model specific details before installing

Revised 26/04/24

WARNING

Please carefully inspect the product before assembling. If you notice any apparent damage, call your carrier claims agent and do not continue the installation until it has been reviewed. Please watch for pinch points. Do not put your fingers between moveable parts. Do not tamper with or disassemble any spring loaded parts. Before installing, make sure that the supporting surface will support five times the combined load of the solution and the hardware. Never exceed the maximum load capacity. Please also layout all components to ensure that you have all of the required parts before proceeding (see BOM list on following page). Use of this product for anything other than its specified use may result in failure or personal injury. This product is intended for indoor use only. We recommend using a qualified trades person for installation. Use an assistant or lifting equipment to lift and position products.

For support, please call: +44 (0)1865 767676 or email: sales@unicol.com



| # | TOOLS REQUIRED |
|---|----------------|
| 1 | n/a |

| INSTALLERS REQUIRED |
|---------------------|
| 1-2 |

COMPONENTS

| # | DESCRIPTION | QTY |
|---|-----------------------|-----|
| 1 | Pop-Out Mount Body | 1 |
| 2 | Adjustable Mount Arms | 2 |

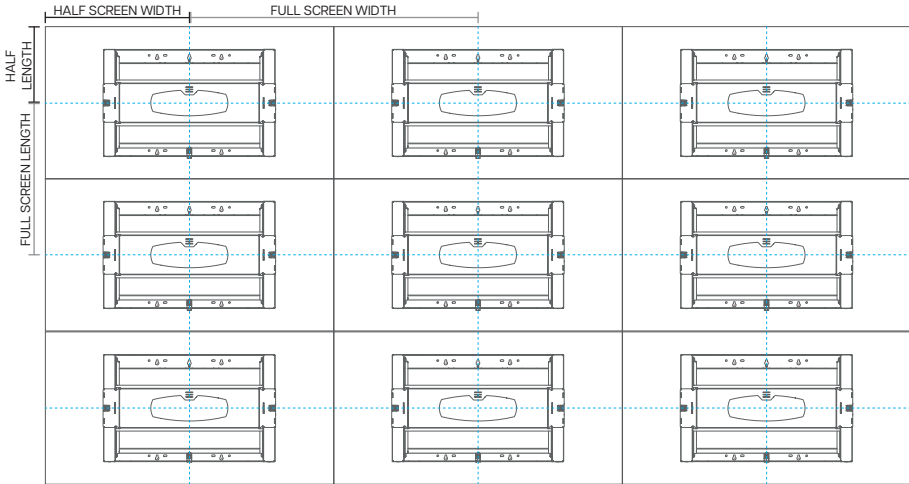

STEP 1

Measure the width and height of the screen(s) to be installed. On the wall, mark out a grid as shown above. Position each mount so that the centreline guides line up exactly with the arrows on the mount body.

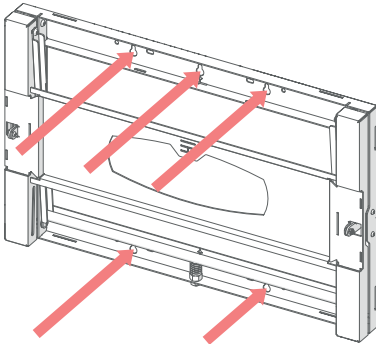

STEP 2

Using the identified mounting slots, fix the mount to the wall.

Please consider cabling and wall fixings prior to installation. Please check surface is capable of supporting 5x the combined solutions weight.

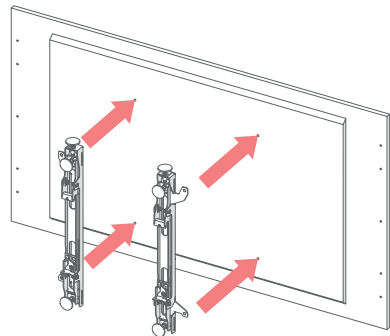

STEP 3

Utilising the fixing pack provided with your mount, attach the arms to the back of your screen.

Ensure the arms are the correct way up before tightening - the 'hook' part of the arm should be at the top.

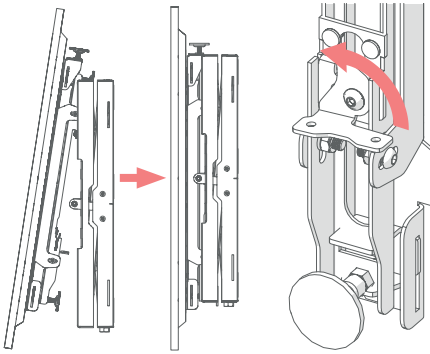

STEP 4

Using another team member, lift the screen up and gradually offer it up to the back plate. Gently tilting the screen forward, hook the arms over the lip of the back plate and lower once in position.

Centre the screen horizontally by sliding from side to side until you are happy with the position. Lock the arms in place by turning the locking lever 90°.

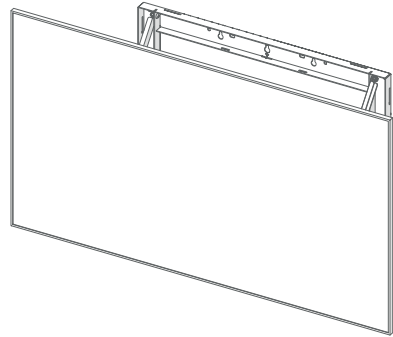

STEP 5

Gently push on the centre bezel of the screen in order to pop the mount out. Alternatively, utilise the optional pop out mechanism pull cord. Cable up.

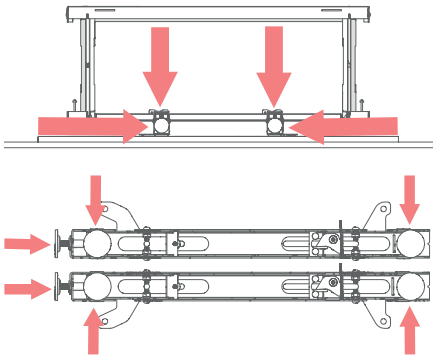

STEP 6

For fine adjustment (up/down and in/out) use the hand adjustable screws on each arm. Make micro adjustments to ensure each screen is level with each other or within an alcove.